

iCon®



## *Materials Handling Products*

- Well tried safety
- Environment friendly
- Economical

  
PROMENS

# iCon® – Well-ried safety

## Packing and transport of hazardous liquids

The iCon® has been fully approved for multi-trip transportation of dangerous products, and has a capacity of 1000 litres. The iCon® has not only achieved the highest possible UN approval but has also undergone a series of intensive field tests. The unit has been designed to have an active life of 10 years meeting the current 5 year legal limit on the liner.



Safe and durable. The new iCon®

## Well-ried safety

The iCon® has passed all international dictated tests and obtained the full UN/ADR approval for transport of hazardous materials. In addition it has been successfully tested and passed the severe requirements of the vibration tests. Extensive field tests have demonstrated that the iCon® can withstand the rigours of every day use.

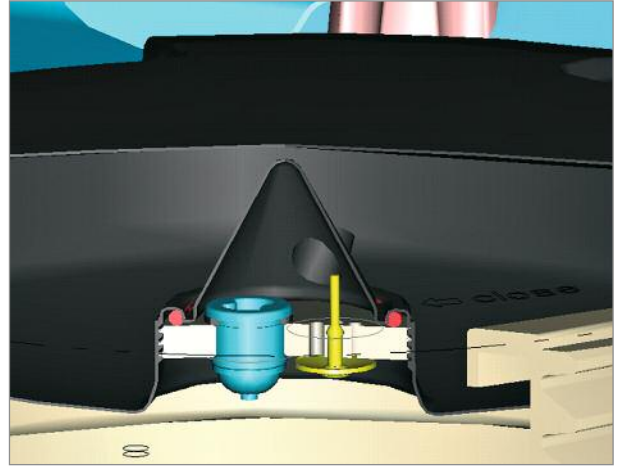

Innovative, lid with integrated vents.

## Well-considered ergonomics

Ease of use and safe handling were central to the design process especially in the critical areas of the lid and valve. The lid has been located to the front and has a sloping cover ensure safe access, in addition the lid has been fitted integrated venting facilities ensuring fast emptying whilst preventing hazardous fumes escaping through an opened man way. The valve has been given enhanced access due to its tilted position.

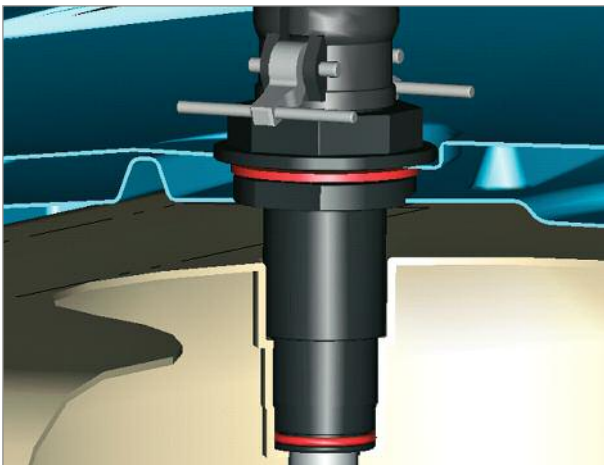

Optional suction tube.

## Spill containment integrated

The iCon® is unique because of its separate spill containments around the bottle and outlet area. The fully banded approach prevents hazardous liquids from escaping into the environment in the event of an incident. The transparent surround in the valve area makes it possible to detect any leakage prior to opening the valve.



Integrated spill containments also in outlet area.

# Environment friendly and economical

## Responsible care

The iCon® is a heavy-duty multi-trip container and has been specially developed to meet the rigours of the distribution industry. Being manufactured solely from polyethylene reduces the demands on the environment and ensures total recyclability can be achieved.

In addition the integrated spill containments around the outlet and bottle prevent leakage into the environment of hazardous products. The iCon® can be returned after its life time for recycling.



## iCon® - All advantages at a glance



## iCon® - Technical information

Length x width	1220 mm x 1020 mm	
Height	1535 mm	
Volume	1000 Liter Netto	
Weight	180 kg	
Maximum weight	2080 kg	
Stack height filled	3 high	
Material container	Bottle XPE, other parts LLDPE	
Temperature range	-20 °C till +40 °C	
Outlet	50 mm ball valve PP (2") with Camlock (DC). Closed (FC)	
Emptying time (closed lid)	7 minutes	
Capacity vacuum vent (optional)	800 cc/min at 20 kPa	
Suctiontube (optional)	ø 25 mm tube, camlock	
UN marking: 31HH1/Y/**-./NL/BONAR PLASTICS 366/8590/2130		
Test medium	Density	Pressure
Water	1,9	110 kPa
Wetting solution	1,6	110 kPa
Acetic acid	(1,6)	(110 kPa)
n-Butylacetat wetting solution	1,6	110 kPa
Mixture of hydrocarbons	1,6	110 kPa
Nitric acid 55 %	1,6	110 kPa
Nitric acid 68 %	1,6	110 kPa
Additional approval	Chromium acid 600 g/l, 69 % nitric acid	
Vibrationtest	DOT-UN §178.819	